

## ModEva™

ModEva is a range of numerical control units intended specifically for sheet metal working.

According to the software installed, it will be used on synchronised or unsynchronised press-brakes of the up-stroking or down-stroking type.

ModEva numerical control units can control up to 18 axes of which 2 are synchronised hydraulic axes especially intended for press-brakes.

The numerical control is composed of 2 main elements:

- the programming console
- the CNC (Computerised Numerical Control).

The programming console is located within the operator's reach, generally fixed to a swivelling arm; the CNC is placed inside the electric cabinet.

The CNC is available in 2 rack formats.

- The rack version **C**  
This is a small, very compact rack, convenient for many situations.
- The rack version **M**

This is a bigger rack permitting a varied combination of configurations.

The software enables manufacturers to configure the axes, the inputs/outputs and the auxiliary functions according to their needs.



ModEva 10S



ModEva 12S

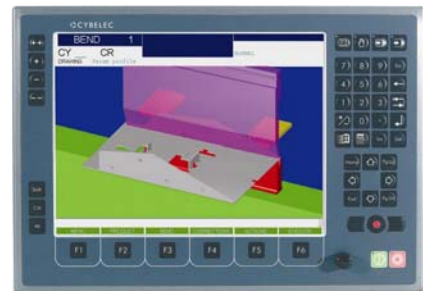

ModEva 15S

## Versions

PS	Version for synchronised press-brakes.
PC	Like the PS but for press-brakes with mechanical (or hydraulic) stops and beam control with a linear measuring rule.
P	Like the PC but without beam control with a linear measuring rule.
PP	Version for folding presses.
ModEva CNC /C	ModEva CNC version "C" (Compact): can control up to 4/6 axes or even 18 with CAN axes*.
ModEva CNC /M	ModEva CNC version "M" (Maxi): controls up to 12/14 axes or even 18 with CAN axes*.

\* see definitions of the axes and configurations further on in the document.

## ModEva range

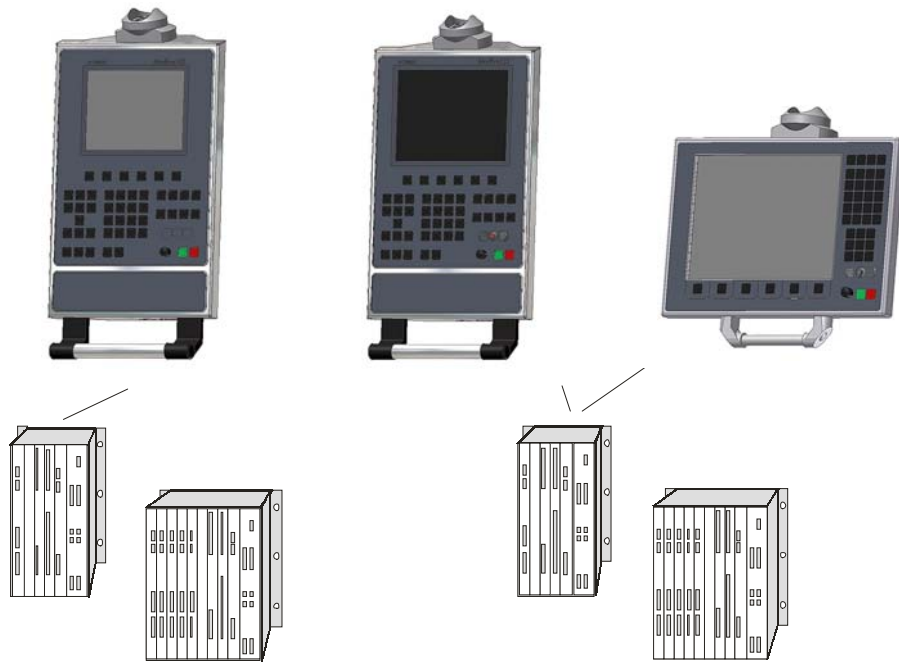

ModEva 10S	ModEva 12S	ModEva 15S
10" screen	12" screen	15" screen
2D	3D	
Windows		

ModEva is a modular range with a choice of:

- 3 programming consoles with 3 screen sizes
- 2 programs and 1 operational system Windows.
- 2 different rack sizes depending on the number of axes and the desired technology (analogue or CAN).

### Definitions:

- Hydraulic axes:** An analogue axis especially intended for controlling the beams (Y1-Y2). These two axes are on the NPU (formerly on the NAX).
- Analogical axes:** Axes whose position is given by an incremental sensor and whose instructions are provided by the CNC via an  $\pm 10V$  DC analogue voltage. One also refers to an analogue interface axis. These axes are controlled by cards called NMX / NSX. Each of these cards controls 2 axes.
- CAN axes:** Axes whose positioning information is handled through a CAN bus. These axes require an NCX card on the CNC side and a CAN interface on the servo-amplifier side. An NCX card can control up to 8 axes. The number of CAN axes is controlled as an option. The ModEva CNC can be equipped with a maximum of 2 NCX axis cards.
- NMX:** A master card for 2 analogue axes. A master card controls up to 3 NSX slave cards.
- NSX:** A slave card for 2 analogue axes. A slave card in all cases requires an NMX card.
- NCX:** CAN card for a maximum of 8 CAN axes. This card can handle various protocols according to the type of servo-amplifier utilised. It is possible to combine CAN and analogue axes.

### Configurations of CNC axes

Rack version	CNC / C		CNC / M					
	2		5					
No. of axis cards	2		5					
Axis position (slot No)	0	1	0	1	2	3	4	5
The most common configurations	NMX	-	NMX	NSX	NSX			
	NMX	NSX	NMX	NSX	NSX	NSX		
	NMX	NLR	NMX	NSX	NSX	NLR		
	NCX	-	NMX	NSX	NSX	NLR	NMX	
	NCX	NLR	NCX	NLR			NMX	NSX

## Configuration of the consoles

Console	ModEva 10S	ModEva 12S	ModEva 15S
TFT screen	10"	12"	15"
Resolution	640x480	800x600	1024x768
Track Sensor	-	Yes	Yes
Touch Screen	-	-	Option
Quick Cursor		Yes	
3.5" floppy		Yes	
Ext. keyboard socket		Yes	Standard AT
Ext. mouse socket		Yes	Serial mouse with mini DIN socket
Power		Through the Panel Link	
Auxiliary I/O		12/12	
Seal		IP 54	
Link CNC	2 cables RJ 45 twisted pair category 6. Cables 5 m or 10 m. Dist. > 10 m with CYBELEC repeater, ModEva 15S > 5 m with repeater		
Temperature, pollution level, relative humidity, during work.	Min. 5° Celsius, max. 40° Celsius.* Pollution level 2. Relative humidity (10 to 85% non condensing). * If the ambient temperature approaches or exceeds 40° Celsius, it would be advisable to install special ventilation, or even air-conditioning..		
Weight	Approx. 10 kg		Approx. 5 kg.

## Configuration of the CNCs

Type	ModEva CNC/x-xx-Px-2DW	ModEva CNC/x-xx-Px-3DW
Software	2D	3D
System	Windows 98 (Lite version for ModEva 10S) Me, NT, XP optional**	
CPU	Kontron 400 MHz	800 MHz optional**
RAM	128 MB	256, 512 MB optional**
Disk	256 MB flash**	Minimum 10 GB HDD**
Network	Yes	Ethernet RJ45
USB 1.1	Yes	
PCMCIA	Optional	Type I and II
Printer port	Yes	
Keyboard input	Yes	PS2
Mouse input	Yes	PS2
Screen output	Yes	STD VGA
Y1, Y2	NPU card	
RS 232 port	Yes	2 of which 1 configurable to RS 422
Serial port for PLC	Yes	1 RS232 configurable to RS 422
Analogue axes	NMX cards, NSX,	according to configuration and rack version
CAN axes	NCX cards	according to configuration and rack version
Sensor inputs	5V DC Line Driver, obligatory complementary signals,	
Digital inputs	NIN cards	32 24 VDC inputs opto-coupled
Digital outputs	NOT cards	32 outputs 24 VDC "sources", max 0.3 A / output
Analogue inputs	NIN cards	6 analogue inputs According to configuration 0-10, 0-24 VDC A/D 8 bits
Analogue outputs Axes and FA	NOT cards	4 outputs 0-10 VDC (8 bits) for the auxiliary functions Z <sub>out</sub> output impedance < 100 Ω , Z <sub>I</sub> load ≥ 10 kΩ
Power supply	24 VDC / max 4A ± 15%	
Seal	Must be installed in an approved electric cabinet.	
Temperature, pollution level, relative humidity during work.	Min. 5° Celsius, max. 40° Celsius.* Pollution level 2. Relative humidity (10 to 85% non condensing). * If the ambient temperature approaches or exceeds 40° Celsius, it would be advisable to install special ventilation, or even air-conditioning..	
Weight	Rack version C: approx. 5 kg.	Rack version M: approx. 6 kg. According to equipment.

\*\* Data may be modified without notice for the proper operation of the numeric control.  
Other configurations on request.

## Auxiliary axes and functions of the standard software

---

The elements listed below are available and can be configured in all numerical controls supplied with standard software (within the number of available axes).

<b>Y1 - Y2</b>	Synchronised axes for the beam (servo-valves, proportional valves).
<b>X, X1, X2, X5, X6</b>	Main rear backgauge axes (X5, X6 generally for gauges external to the frame).
<b>X1 ABS, X2 REL</b>	Secondary gauge axes in absolute or relative mode.
<b>R, R2, R5, R6</b>	Backgauge height-adjustment axes (R5, R6 generally for gauges external to the frame).
<b>Z, Z2, Z5, Z6</b>	Axes for left/right movement of the backgauge.
<b>M1, M2</b>	Axes for the adjustment / movement of the die.
<b>Conical folds</b>	Comfortable programming for conical folds (requires X, X2 and adapted stop fingers).
<b>Free 1, 2, 3, 4</b>	Independent axes without any particular control.
<b>Pressure</b>	Voltage output for pressure valve control. Should current control be wanted, the MVP 100 accessory, which is an external amplifier module to be fitted in the electric cabinet, would be necessary (see the MVP 100 data sheet).
<b>Crowning</b>	Voltage output for adjusting the hydraulic crowning. Should current control be wanted, the MVP 100 accessory, which is an external amplifier module to be fitted in the electric cabinet, would be necessary (see the MVP 100 data sheet). or 24 VDC (SP, SN) outputs and potentiometric position transducer for adjusting the mechanical crowning (Wila type).
<b>F1 to F10</b>	Configurable auxiliary functions (possibly, the number of AFs may be limited according to the type of function and management). 24VDC voltage or logical order outputs, with or without position control by means of a potentiometric transducer. Special controls for gauge fingers, bending aids, die movements.
<b>Languages</b>	French, German, English, Italian, Spanish, Portuguese, Swedish, Danish, Finnish, Dutch, Hungarian, Polish, Czech, Slovene, Russian, Turkish, Chinese, Taiwanese. Other languages on request.
<b>Angle measurement</b>	Automatic correction by means of the angle measurement in serial link with digital angle protractor Mitutoyo or other compatible systems.

## Optional auxiliary axes and functions and other options (at extra cost)

---

<b>M1 M2 mounting</b>	Axes for the adjustment / movement of the die in relation with the choice of tool mounting.
<b>X3, X4, X7, X8</b>	Front gauge axes (not calculated).
<b>Z3, Z4, Z7, Z8</b>	Front gauge axes (not calculated).
<b>H, H2</b>	Rear sheet support axes (not calculated).
<b>H3, H4</b>	Calculated front sheet support axes.
<b>AP1-AP4</b>	Calculated front / rear folding assistance axes.
<b>CAN axes</b>	The number of CAN axes is optionally controlled.
<b>Angle measurement</b>	Option permitting the adaptation of an angle-measuring system during the folding.
<b>Thickness measurement</b>	Option permitting the automatic correction of the depth calculation by using external sheet-metal thickness measuring equipment connected by RS 232.
<b>Axis thickness measurement</b>	Option permitting the automatic correction of the depth calculation by using external thickness measuring equipment connected to an axis card. The measurement is taken using conventional encoders.
<b>Message interpreter</b>	Option for the complete remote control of the CNC via network or RS 232. Reading/writing of variables, corrections, part loading, mode changing, etc. Ideal for automation and/or applications with robot. Possibility of connecting the results of an external program.
<b>Other</b>	There exist numerous options specific to each constructor. Other options can be developed according to needs.

## Hardware options

<b>Touch Screen</b>	Touch panel for ModEva 15S.
<b>USB CD reader</b>	External USB CD reader, self-powered by the USB card (for Windows models).
<b>Hand-grips</b>	For ModEva 15S console, choice of 2 models.
<b>Auxiliary panels</b>	Auxiliary panels for Lazer Safe commands, virgin or customised auxiliary panels for ModEva 10 / 12 or 15S
<b>Fixing adapter Sserie</b>	Adaptation plate for the ModEva 10S and 12S, allowing the installation of a ModEva 10S or 12S on a pendant arm of ModEva 10 or 12 or DNC 1200.
<b>Earthing kit</b>	Rail and bridles for earthing the sheathing for the ModEva CNC rack. See photo below.
<b>CAH / CAB</b>	Interface card for proportional Hörbiger, Bosch valves.
<b>MVP 100</b>	Voltage / current conversion module (0-10V → 0,25-0,5 / 0-2 A) for pressure and crowning valves, to be fitted in the electric cabinet.
<b>MSV</b>	Voltage / current conversion module (0-10V → 0-50 mA, 0-300 mA) for servo-valves.
<b>5-24 interface</b>	5VDC–24VDC interface for remote I/O programming console ports. This interface connects to the ModEva CNC CPU. On demand.

## EC Directives

Directives Our numerical control units comply with Directives 89/336/EEC and 73/23/EEC

## Overall dimensions

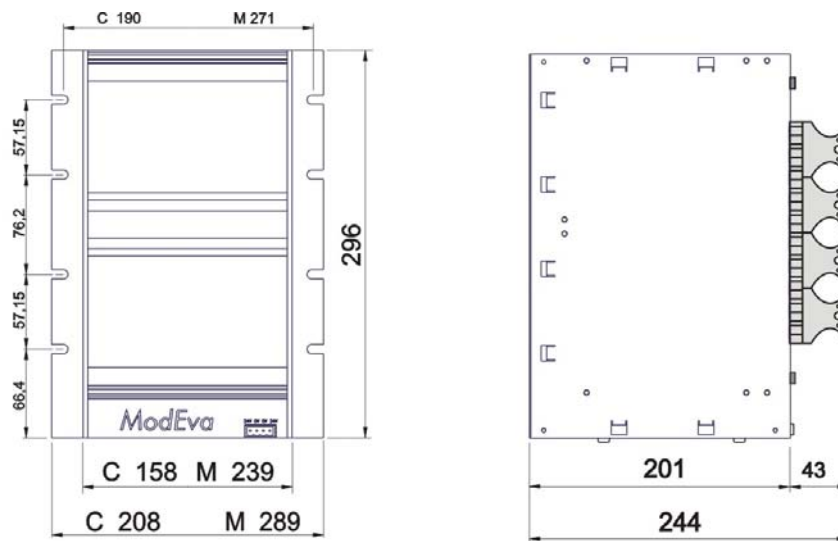

**CNC / C**

**CNC / M**

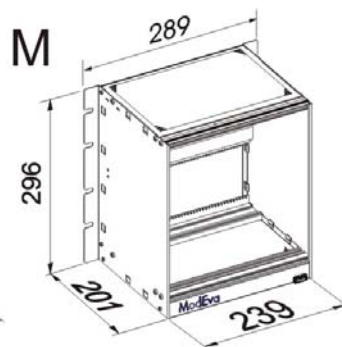
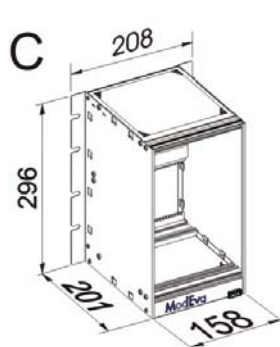

Earthing kit



**ModEva 10S and ModEva 12S**

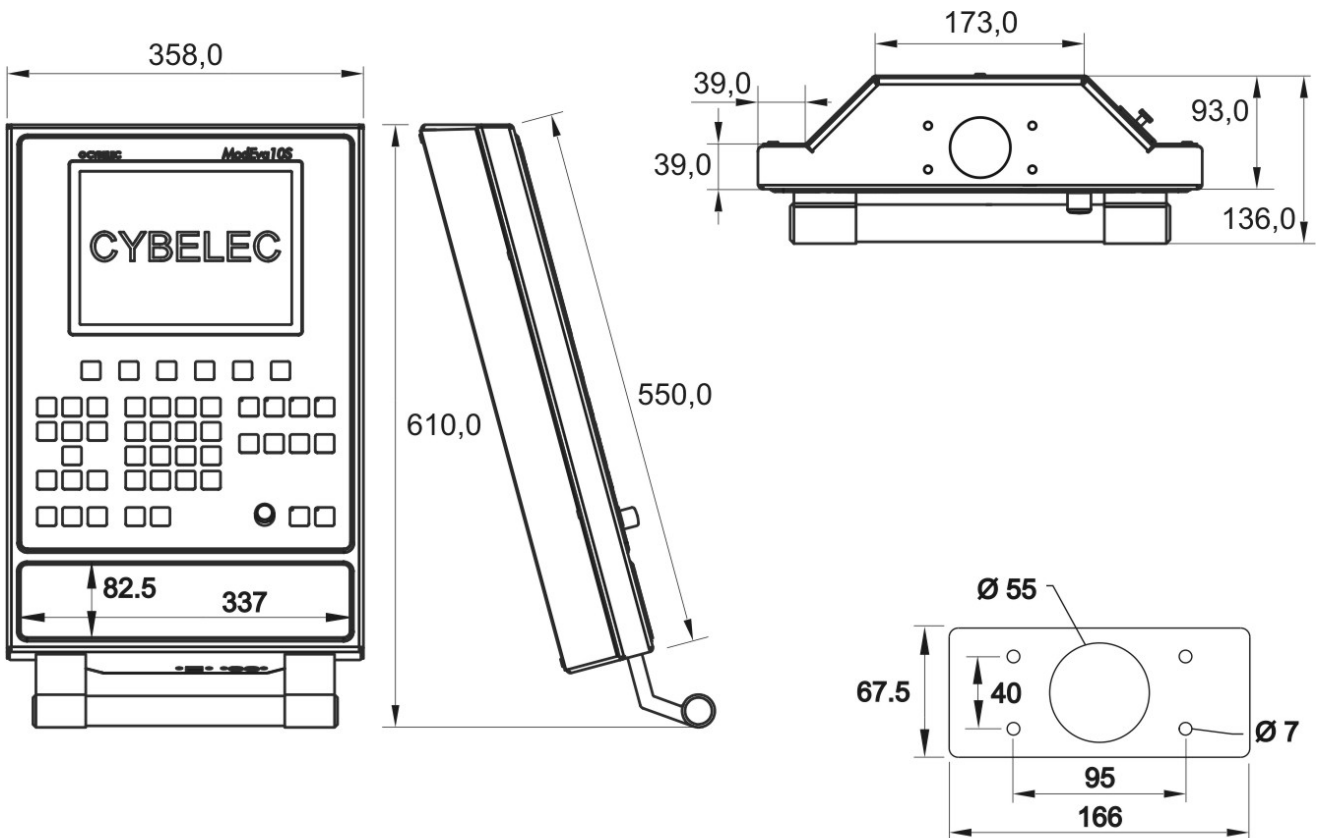

**ModEva 15S**

Rittal CP-L6525.100 or 600  
+ Rittal CP-L6527.100

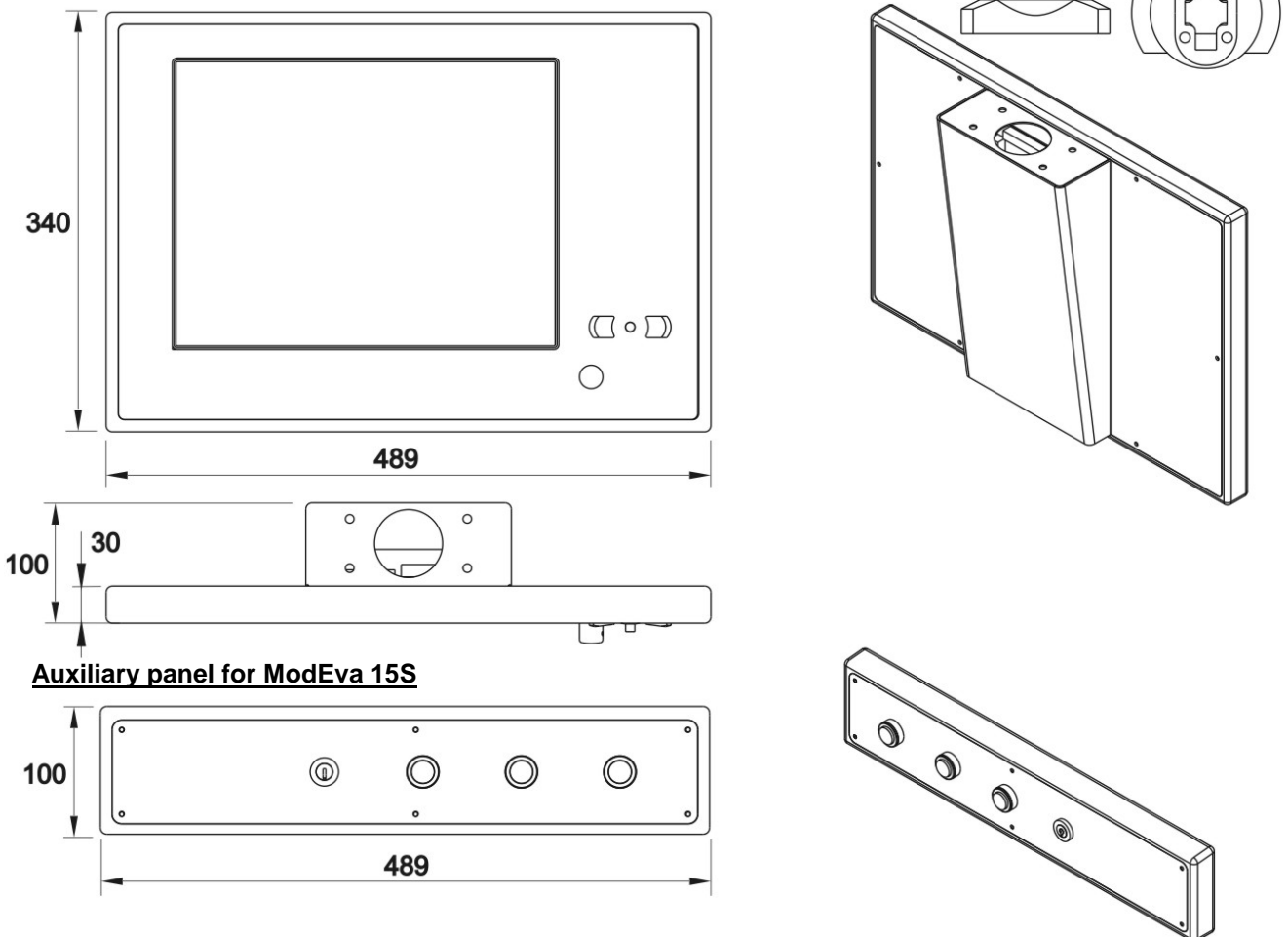

Modification rights reserved